

5

Acoustic Seating

Customised Acoustic Solutions

Products



AOS – Editorial	3
<i>Who we are & what we stand for</i>	4
<i>Material and Surface – Colour / Texture / Materiality / Functionality</i>	7
Products	10
<i>Acoustic Seating Elements</i>	12
<i>Silence Point Lounge</i>	16
<i>Silence Point Concept</i>	19
<i>Silence Point TouchDown</i>	23
<i>Silence Point WorkBench</i>	27
<i>Silence Point WorkBench Top</i>	31
<i>Silence Point Stream</i>	34
Fabrics & Materials	37
<i>AOS Fabric Collection</i>	38
<i>Acoustic Filling</i>	39
Contact / Impressum	41

Note: This digital brochure contains direct links to the AOS homepage. Please just follow the signs

More information [... >>](#)

Note: The AOS logo will take you directly back to the table of contents from any page.



More efficiency through better working conditions - that is the goal and at the same time the solution approach for our services and products.

PASSION FOR EXCELLENT ROOM ACOUSTICS AND SOUND INSULATION - AOS stands for excellent room acoustics and sound insulation at the office workplace like no other company in the field of office and object furnishing. More efficiency through better working conditions - that is both the goal and the solution approach for our services and products. Many years of experience, an order-related and high vertical range of manufacture at the company's location in Schopfloch enable us to develop and implement the optimum solution for your project together with you. Thanks to our product solutions and services, open and flexible office structures are accepted and appreciated not only by employers but also by employees.

Who we are & what we stand for



Technisches Datenblatt für Wandabsorber 55, H=800 mm, B=1200 mm, Dicke 55 mm

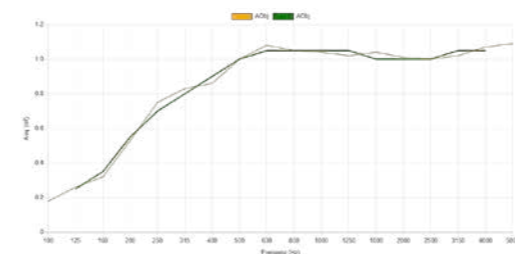

Frequenz f (Hz)	Terzen As (m²)	Oktaven Ap (m²)
50	0.02	
63	0.08	
80	0.11	
100	0.18	
125	0.26	0.25
160	0.32	
200	0.53	
250	0.75	0.70



Absorber
 Bezeichnung Wandabsorber 55, H=800 mm, B=1200 mm, Dicke 55 mm
 Hersteller AOS Akustik Office Systeme GmbH

An order-related and high vertical range of manufacture at the company's location in Schopfloch enables the optimal solution for your project.



High advisory competence & intensive dialogue with customers - A high advisory competence of our employees and the intensive dialogue with our customers offer security for the best room acoustic results. Our services are a guarantee for a healthy and performance-promoting working and living atmosphere and they fulfil the highest design and quality requirements. Our products and services are not only used in office environments, but also in educational and social facilities, in meeting and conference centres and in private homes.

Intensive dialogue provides security for the best room acoustic results.

Flexible production & high vertical range of manufacture - Since the early days, AOS has attached great importance to vertical range of manufacture. The entrepreneurs only purchase raw materials and carry out all work steps on site with their own employees. Production takes place in four halls in Schopfloch, Middle Franconia. Here, the self-developed aluminium profiles are processed and assembled, and the solid wood and wood-based materials are cut to size and processed. In the sewing department, which is strongly affected by growth, the fabric covers are cut, sewn and prepared for final assembly. At the same time, the various acoustic fillings and superstructures are made up in a specially developed process. AOS wants to be able to react flexibly to every customer order and ensure quality on site. "We do not manufacture off the peg." emphasises one of the company founders. "Each element is only cut to size when the order is received. We only store raw materials here in Schopfloch, the further processing is entirely in our hands."



"We do not manufacture off the peg."

Material and Surface

Colour / Texture / Materiality / Functionality

What criteria define the orientation, functionality and comfort of a working environment today? The material (physical) and its materiality (context: material / human / environment) are increasingly perceived by the user as a quality feature. The following applies here: the more reduced the form of a product, the more important its material. The focus here is particularly on textile surfaces, as these play a decisive role in almost all products in the AOS portfolio.

The choice of surfaces and materials is about analytical perception, and even more about sensual perception. The first visual clue to trigger emotions is the colour. By touching the surface, the user can experience the product haptically for the first time. Whether, in the case of a textile, its texture feels velvety, soft or scratchy is decisive for the effect of the object. Selected material, colour and texture combinations can be harmoniously juxtaposed or set exciting contrasts and contribute to an inspiring working atmosphere.



Material (quality) is increasingly perceived by the user as a quality feature.

Colour choice, this is not exclusively an aesthetic question: it establishes the connection to the corporate identity and has an influence on the subconscious. It can promote performance, concentration, inspiration and communication and, last but not least, increase the well-being of each individual employee.

Today, a well thought-out colour concept that reflects not only fields of activity but also the values of the company is an important building block towards an ergonomic office. The associations associated with colours are manifold.

Colour and lighting in the office are among the soft factors in ergonomics.

Red stands for warmth and activity, for dynamism and energy, for creativity and self-confidence. Negatively, it is associated with danger, anger, excitement or aggressiveness. Red is suitable for all areas in your company where work is done, so also for team workplaces or conference rooms.

Yellow, seen positively, stands for happiness and contentment, for creativity, alertness, optimism and joie de vivre. It influences harmony, relaxation and makes you cheerful. Yellow prevents tiredness and fatigue. Negatively, yellow stands for envy and jealousy. Yellow is well suited for relaxation zones in your company. Here, the appetite-stimulating and relaxation-promoting properties of this colour come into their own.

Blue has a calming and relaxing effect. Positively, it stands for accuracy, concentration, courage, clear thinking, learning, self-confidence and development processes. Negatively, it stands for coldness or melancholy. Use the colour blue when you want to work quietly and are faced with difficult problem solving. If you use a separate meeting room, blue is a good choice because it promotes clear thinking and self-confidence among your meeting participants. There is a greater chance of achieving common meeting goals in a relaxed atmosphere.

Effects of the primary colours red, blue and yellow



Another trend is to look analytically at materials in their broader context, i.e. the relationships and interactions with people and the environment, not just the physical properties. Sustainability and longevity are important keywords here. Fabrics made from renewable and sustainably produced raw materials, natural fibres such as virgin sheep's wool, flax and FSC®certified wood. Furthermore, recycled materials such as aluminium with a high recycled content or textiles made of recycled polyester fibres are important selection criteria.



Basically, the technical performance of a material for the intended use must always be assessed. For example, an upholstery fabric for seating furniture. Is the fabric designed for seating surfaces and not for vertical surfaces? What else needs to be considered. First of all, it is not only the abrasion resistance of textiles that guarantees a long service life. Technical properties for processing, flammability and acoustic properties are increasingly important. Lightfastness or proper care and maintenance, these are all important criteria that play a role in fabric selection.

The evaluation and decision for or against a material(s) should therefore be based on a whole range of different criteria.

Sustainability and longevity are important criteria when considering the material and its interactions with people and the environment.

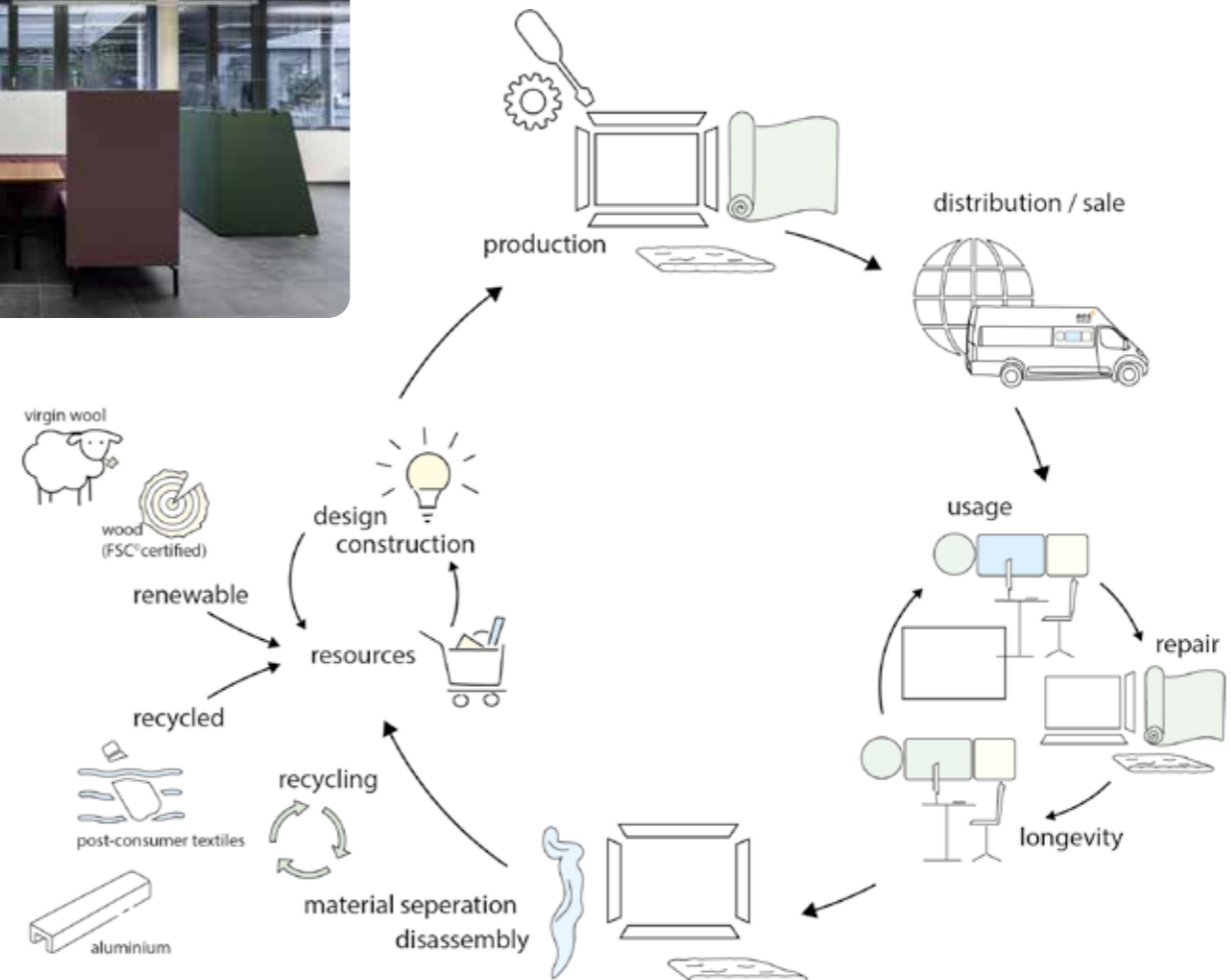

*DESIGN DIVERSITY AND
CUSTOMISED ACOUSTIC
SOLUTIONS*

AOS offers design diversity and customised acoustic solutions off the beaten track and uniformed concepts. High-performance products with personality and character, manufactured with a high level of technical expertise and a great deal of attention to detail. A uniquely broad product range and a wide variety of variants offer almost unlimited design possibilities.

Products

Variety of Acoustic Solutions



Acoustic Seating Elements

Flexible office structures with improved acoustics

Whether in the lounge or in open office and project areas, the acoustic seating elements can be used almost anywhere. At the same time, they differ significantly from ordinary seating furniture. Whether they are a cylinder, a cube or bench, they all have a highly sound-absorbent core in combination with excellent seating comfort. This means that they not only make a valuable contribution to the design and implementation of flexible office structures, but also make a significant contribution to improving room acoustics and audibility at the workplace. Equipped with a fitting that can be adapted to the adjustable feet, the elements can be connected to each other in a stable and flexible manner. A fabric cover that can be quickly and easily removed, professionally cleaned or, if



necessary, replaced is invaluable for seating furniture.

Designed for a seat height of 450 mm, the cubes have an edge length of 450 x 450 mm. 9 fabric collections in different qualities and weaves offer plenty of scope for individual design.

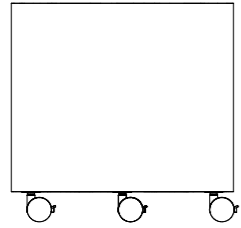

Optional version with castors in view. Top: Cylinder Bottom: Cube as 1-, 2- or 3-seater.

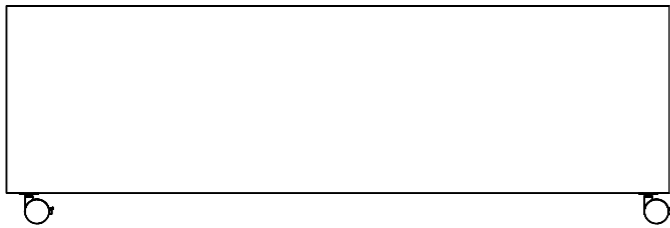
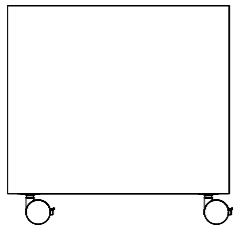

As a cylinder, a cube...

Acoustic Seating Elements

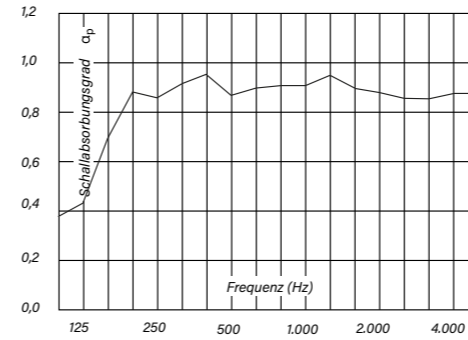

Sound absorption level - octave centre frequency

*The AOS fabric edge:
Highest quality
craftsmanship
with attention to
detail.*



Acoustic seating elements can be used almost anywhere.





Because whether cube or bench: what they have in common is a highly sound-absorbing core combined with very good seating comfort.



... or a bench.



*Designing office space and functions
in an agile and modular way.*



*The acoustic seating elements fulfil all
the prerequisites for a contemporary,
agile working environment: they create
creative opportunities for communication,
collaboration and chance encounters,
and incidentally they optimise the room
acoustics.*

[Acoustic Seating Elements >>](#)

Silence Point is a versatile product family with the best acoustic properties, developed and optimised over many years. The modular system is broadly based and ranges from the classic museum bench and various sofa versions to the complete work island with or without a roof. The **Silence Point Lounge** models are not only at home in exclusive lounges, as the name suggests, they have also long since found their way into modern and open office spaces. Whether with or without backrest, the inviting models offer a high level of seating comfort and are equipped to meet the ergonomic requirements of everyday office life and its surroundings. There is a choice of 9 fabric collections with an almost unlimited variety of structures and colours. Among them is the "Passion" fabric with its beautifully textured woollen weave and strongly structured surface. The classic museum bench as a one-seater or two-seater convinces with its clear and restrained design language as a solitaire or charmingly combined with a backrest. Equipped with a soft back cushion, these invite conversation or simply to linger.

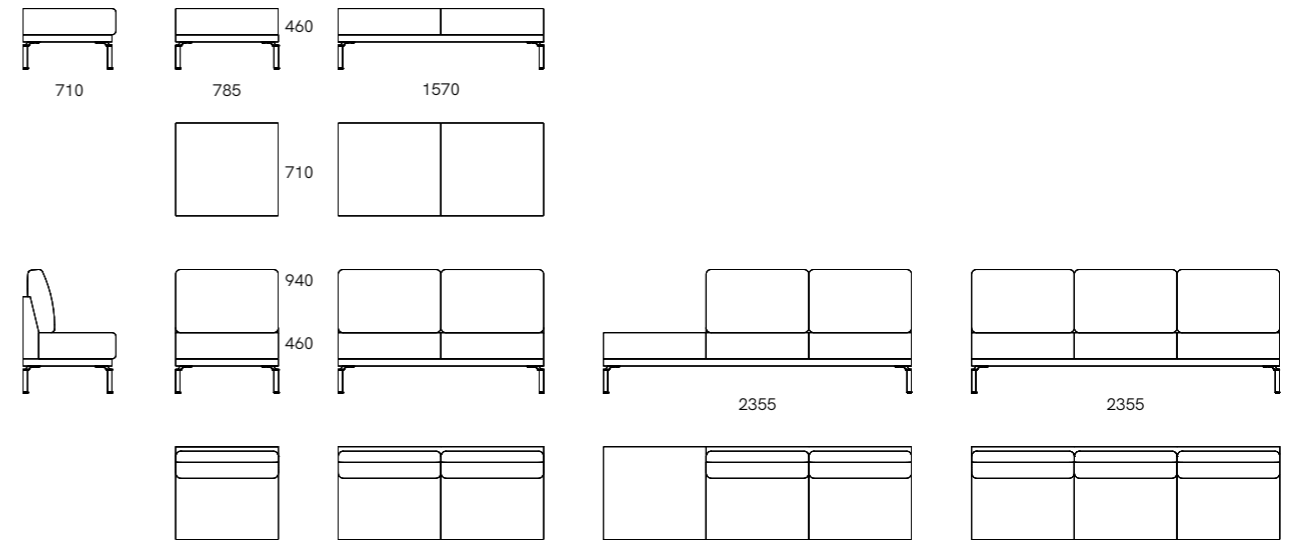

Silence Point Lounge

*Clear shape
with soft character*

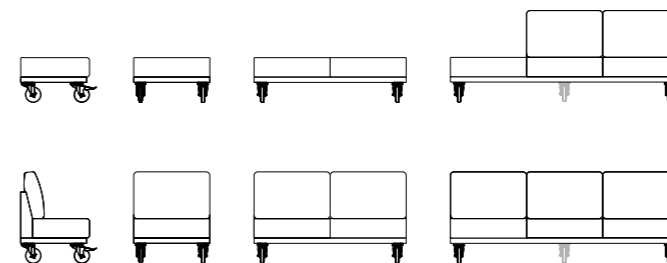

*Optionally, all models
can be configured to be
configured on castors.*



Bench (1-Seater)



Bench (2-Seater)



2/3-Seater



1-Seater



2-Seater



3-Seater

*With or without
backrest, the inviting
models have a high
seating comfort.*



Here in combination with acoustic partition walls.



Bench (2-Seater)



Silence Point >>

Silence Point Concept

Wall construction highly sound-absorbing

Straightforward and unfussy in design and with an immensely comfortable seat and backrest upholstery, the **Silence Point Concept** models have the potential to become a "favourite place". Whether on the open office space, in the staircase or in the reception area, the models available in three heights, from 1100 mm to 1400 mm to 1700 mm, create islands of peace and relaxation. What remains hidden from view, the wall construction is highly sound-absorbent at its core and thus ensures excellent comfort. The models are available as one-, two- or three-seaters. There is a choice of 9 fabric collections for the wall construction with an almost unlimited selection of structures and colours. Seating comfort and ergonomic features with invitingly soft back cushions are designed to meet the demands of everyday office life and its surroundings. The walls, which are lovingly upholstered in detail, are also available in the quilted version 114 partial (standard) on one or both sides. For this purpose, 8 fabric collections with different characters are available.

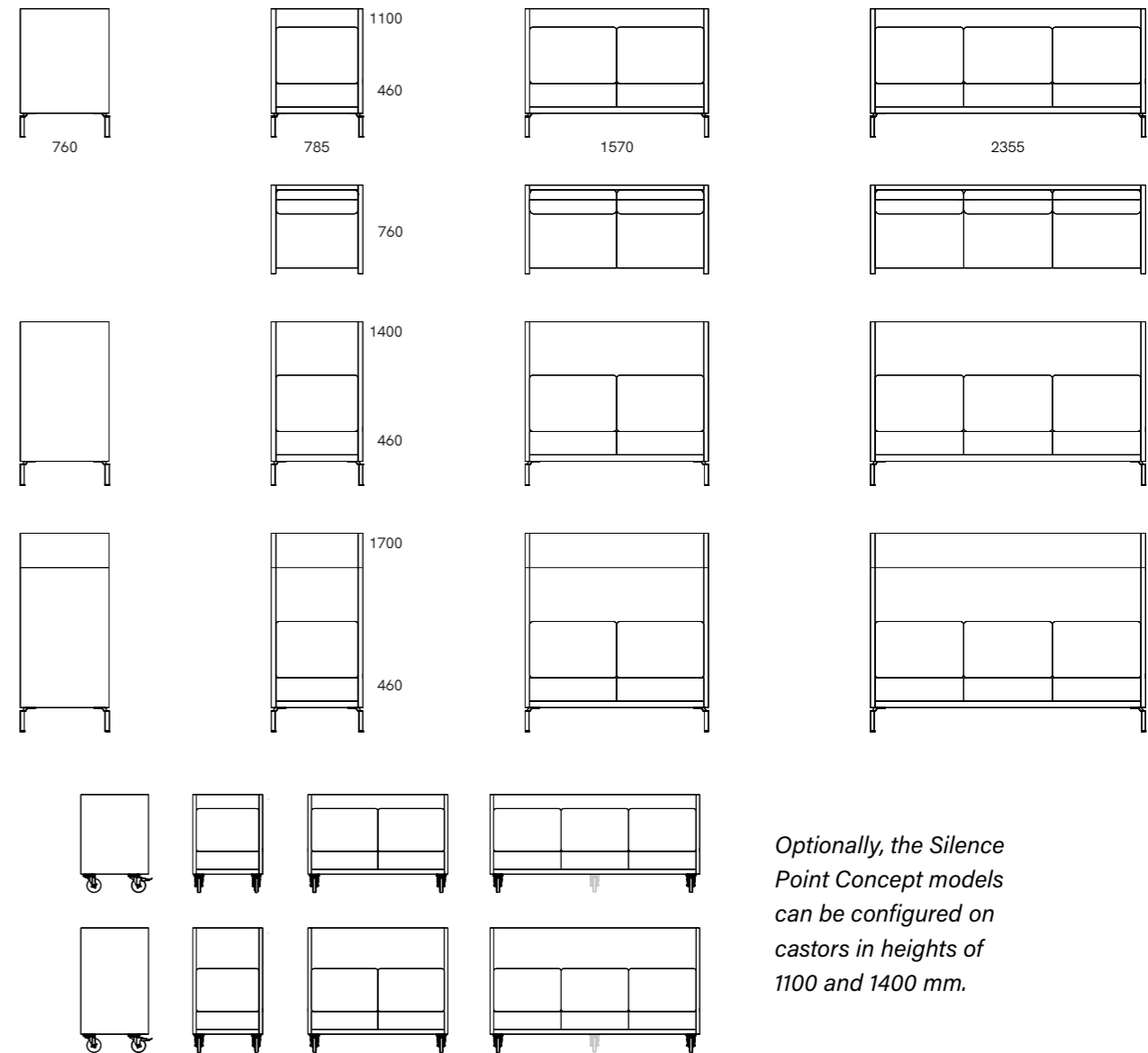

Optionally, the Silence Point Concept models can be configured on castors in heights of 1100 and 1400 mm.



1-Seater



2-Seater



3-Seater

*Model overview:
Three widths &
three heights*



Height 1100



Height 1400



Height 1700



No quilting



Quilted on one side outside



Quilted on both sides

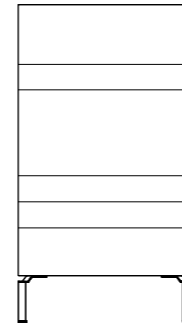

Quilting (standard)
114 partial

Using the example of height 1400 mm

Silence Point 40

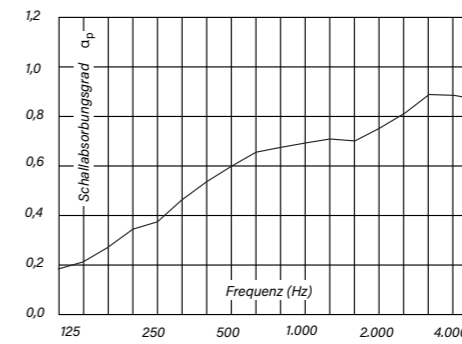

Sound absorption level – octave centre frequency

Variety of quilting: In addition to the standard, individual quilting variants are possible on request.



Whether on the open office space, in the staircase or in the reception area, the Silence Point models create islands of peace and relaxation.



What remains hidden to the eye, the wall structure is highly sound-absorbent at its core.

[Silence Point >>](#)

Silence Point TouchDown

Ergonomics and good acoustics

See, hear, feel: When these three sensory stimuli fit together perfectly, places full of harmony and ideal conditions for creativity are created. The **Silence Point TouchDown** models stand for ergonomics, seating comfort and good acoustics. At the same time, with a width of 1210 mm, they are extremely space-saving. In addition to the choice of 9 fabric collections, further design features ensure design diversity. The walls, which are lovingly upholstered in detail, are available with quilting on one side or optionally on both sides. For this purpose, 8 fabric collections with different character are available. The models are available with or without a desk shelf. Just as contemporary, a configuration on castors is also possible.

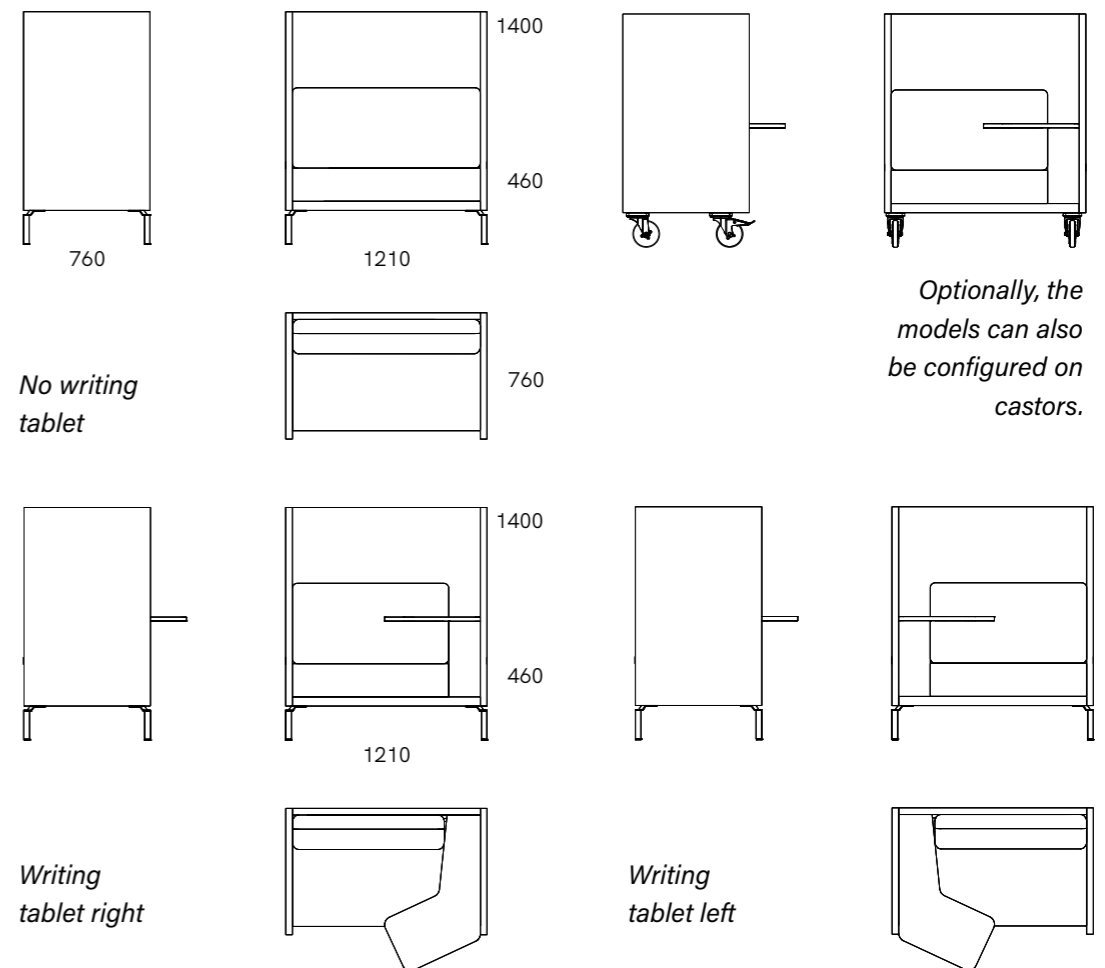

Optionally, the models can also be configured on castors.

*Quilted
on both
sides*



*Quilted on
one side
outside*



No quilting

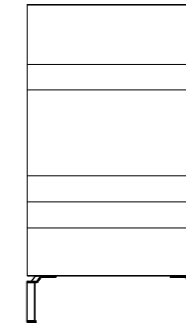

*Quilting
(standard)
114 partial*

*Ergonomic plus: a desk
shelf can be placed on the
right or left.*



*Writing
tablet left*



*No
writing
tablet*



*Writing
tablet right*



Silence Point 40

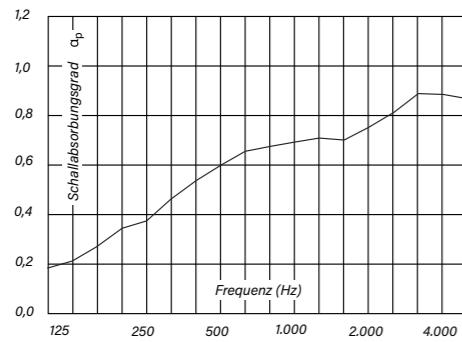

Sound absorption level - octave centre frequency



Contemporary: Agilely configurable on castors.

Silence Point TouchDown models thus stand for significantly more ergonomics, seating comfort and good acoustics.



Silence Point >>

Silence Point WorkBench

Consistently straightforward and technically timeless

Whether it is a work island, meeting point or quiet zone, **Silence Point WorkBench** always presents itself as an eye-catcher with a sovereignty bordering on serenity. The straightforward, classic design language is the result of the reduction to a few decisive functions. For one person, the **Silence Point WorkBench** is a workspace for creative meetings in a small team; for another, it is a place of retreat for concentrated work and quiet conversations. With a footprint of approx. 2200 mm x 1600 mm, they are extremely space-saving and can also be used in the immediate vicinity of lively and restless zones thanks to the best acoustic values in terms of sound absorption and sound shielding. Wall heights from 1400 mm up to 1700 mm, in combination with 9 fabric collections, offer architects and acousticians a great deal of design freedom. The walls, which are lovingly upholstered in detail, are offered in a quilted version on one side or optionally on both sides. For this

purpose, 8 fabric collections with different characters are available. An optional electrification module (PowerDot) integrated into the work table makes the system independent of the office infrastructure.

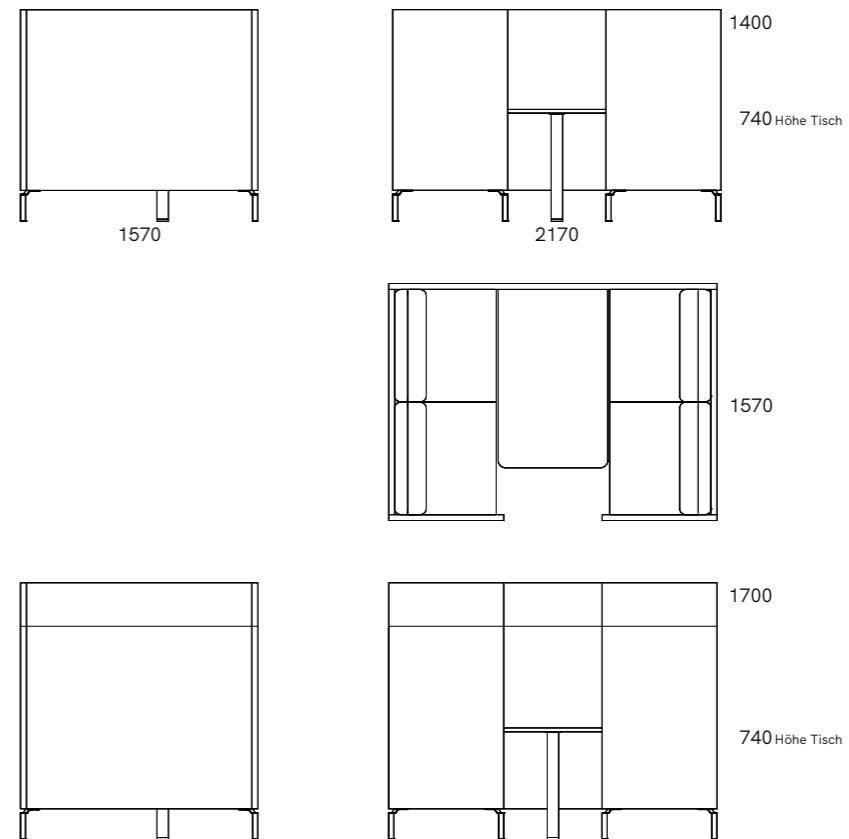



Whether it's a work island, meeting point or quiet zone, Silence Point WorkBench always presents itself as an eye-catcher in the room.

Various versions in height 1400 mm.



No quilting

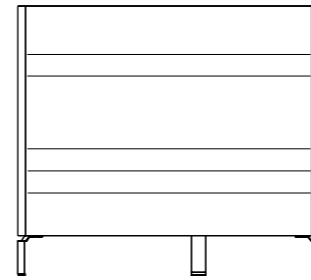

Example
Height 1400 mm

Quilting
(standard)
114 partial

Quilted on one side outside



Quilted on both sides



Example
Height 1700 mm

Viefalt quilting:
In addition to the
standard, individual
quilting variants are
possible on request.



Silence Point 40

Due to the best acoustic values in terms of sound absorption and sound shielding, the Silence Point WorkBench can be used in the immediate vicinity of lively and noisy zones.

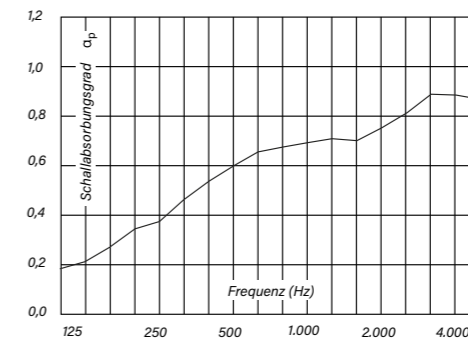

Sound absorption level – octave centre frequency

Silence Point WorkBench height 1400 mm

[Silence Point >>](#)

Silence Point WorkBench Top

*Acoustically highly
efficient & extremely
space-saving*

Like its close relative, the Silence Point WorkBench, the **Silence Point WorkBench Top** with roof is an eye-catcher for any room. All the more so because the beautifully curved roof with integrated LED usually towers far above other furnishings. The straight-lined classic design language is the result of the reduction to the decisive functions. Thus, for one person, the **Silence Point WorkBench Top** becomes a workroom for creative meetings in a small team, for another a place of retreat for concentrated work and for quiet conversations. The vaulted roof over the entire WorkBench ensures that concentrated work or lively discussions are also possible in open spaces with a high ceiling height. With a footprint of approx. 2200 mm x 1600 mm, they are extremely space-saving

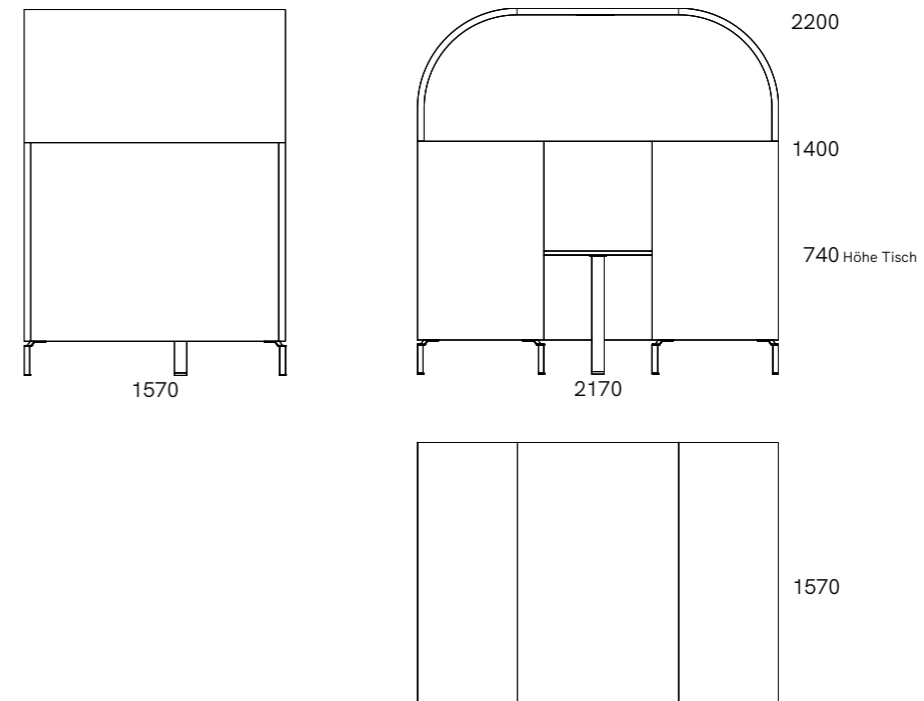

despite the best acoustic values in terms of sound absorption and sound shielding. There is a choice of 9 fabric collections with an almost unlimited selection of structures and colours for the wall construction. The walls, which are lovingly upholstered in detail, are offered in a quilted version on one side or optionally on both sides. For this purpose, 8 fabric collections with different characters are available. An LED light integrated in the standard or an optional electrification module (PowerDot) integrated in the work table make the system independent of the office infrastructure.

No quilting

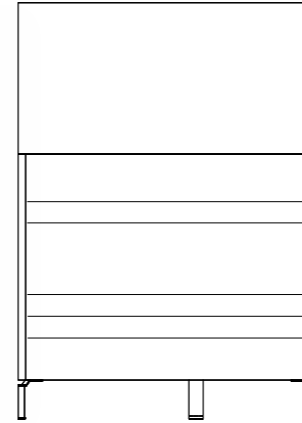

Quilted on one side outside



Quilting (standard) 114 partial

Quilted on both sides



Silence Point 40

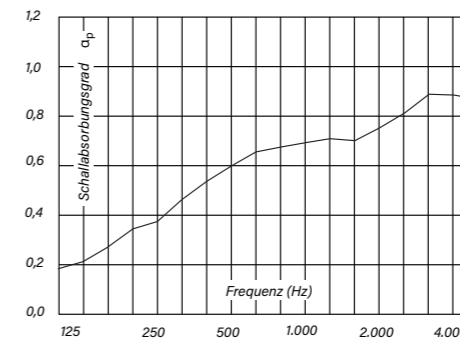

Sound absorption level - octave centre frequency



[Silence Point >>](#)

Silence Point Stream

An expressive acoustic object

A clear design language and excellent seating comfort, **Silence Point Stream** combines function and modern design with an extra portion of cosiness. The inviting models are at home in open office spaces, hotel lounges, stores and showrooms, among other places. Available in two heights of 940 and 1100 mm, the models create comfortable islands to linger and relax. What is hidden from view, the wall structure is highly sound-absorbent at its core and thus contributes to good room acoustics. The models are available as one-, two- or three-seaters. The following are available for the wall construction 9 fabric collections with an almost unlimited choice of textures and colours. This is how the **Silence Point Stream** models become a favourite place with character and an unmistakable appearance. Seating comfort and ergonomic features with invitingly soft back cushions are geared to the

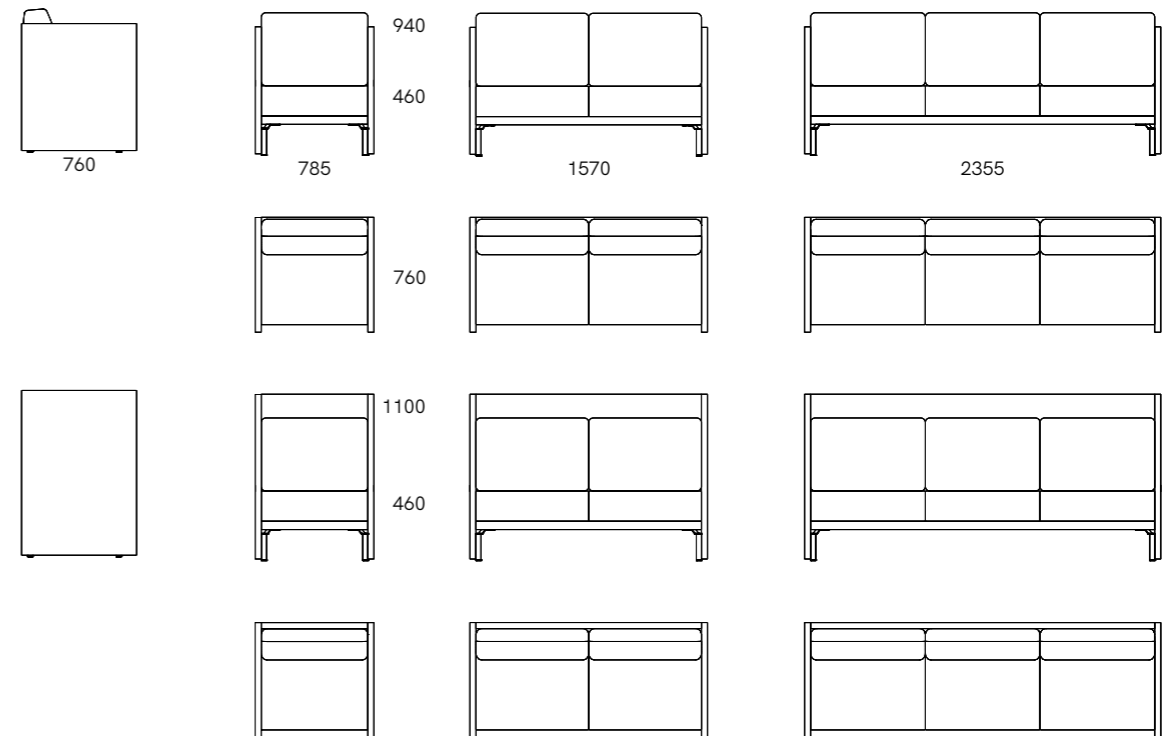

requirements of the project. The walls, which are lovingly upholstered in detail, are offered in a quilted version on one side or optionally on both sides. Here 8 fabric collections with different character are available.



*Model overview:
Three widths &
two heights*



No quilting

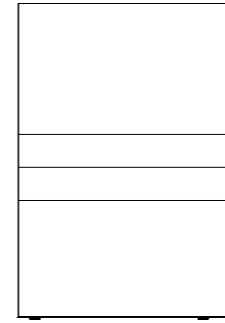

Example height
1100 mm

Quilted on one side outside



Quilting
(Standard)
114 partial

What remains hidden to the eye, the wall structure is highly sound-absorbent at its core and thus contributes to good room acoustics.

Quilted on both sides





Silence Point Stream 3-Seater



Silence Point >>



A wide range of fabrics is available for **AOS Akustik Office Systeme** products. Only a limited selection can be shown here.

For more information visit us directly at

www.akustik-office-systeme.de



Polyester



Recycled Polyester



Trevira CS



Wool

Fabric	Material	Look	Width
Medley	Polyester	Melange	1.400 mm
Cura	Recycled Polyester	Two-coloured	1.400 mm
King L	Trevira CS	Uni/Two-/Three-coloured	1.400 mm
Roccia		Two-coloured/Melange	1.400 mm
Blazer	New sheep's wool 100 %	Felt	1.400 mm
Connect	New sheep's wool 48 %, Recycled Polyester 41 %	Melange	1.400 mm
Crisp *	New sheep's wool 93 %, Polyamid 7 %	Melange	1.400 mm
Main Line Flax	New sheep's wool 70 %, Flax 30 %	Melange	1.400 mm
Passion	New sheep's wool 91 %, Polyamid 9 %	Multicoloured	1.400 mm

* NOT possible in the quilted version



Standard: Polyester nonwoven

– 100 % PES fibres

Polyester nonwoven ...

- is recyclable by type.
- consists of approx. 60 % recycled fibres.
- is highly sound-absorbing and reduces reverberation.
- is extremely durable and moisture-resistant.
- is without chemical additives.
- is certified according to Standard 100 by OEKO-TEX®.
- is skin-friendly and allergy-friendly.
- Flame resistance according to DIN 4102: PES nonwoven B1



Optionally: Pure new sheep's wool

– 100 % sustainable

New sheep's wool ...

- is renewable, natural and regional.
- is highly sound absorbent and reduces reverberation.
- is moisture regulating.
- is non-allergenic.
- breaks down pollutants.
- neutralises odours.
- is permanently biocide-free protected by Ionic Protect®.
- has an antibacterial effect.
- Fire protection according to EN 13501: Sheep wool insulation D-s2 d0; Sheep wool felt C-s2 d0;
- is self-cleaning.



www.akustik-office-systeme.de

Impressum

published by
Akustik Office Systeme GmbH
Lenabergweg 5
D-91626 Schopfloch

Editor
Henrik Behnert, AOS

Graphics / Illustration
Sabine Fleischmann, AOS

Photos
Damian Tauchert, Berlin
for AOS

except
Renderings Silence Point Series
page 18 Silence Point Lounge, intern
page 26 Silence Point TouchDown, intern
page 39 Polyestervlies, intern

@2024



Akustik Office Systeme GmbH
Lenabergweg 5
D91626 Schopfloch

Phone+49 9857 97559-0

Fax +49 9857 97559-29

info@akustik-office-systeme.de

www.akustik-office-systeme.de