

# Silence Line

## 2 Structuring the Room

*Customised Acoustic Solutions*

---

*Product*

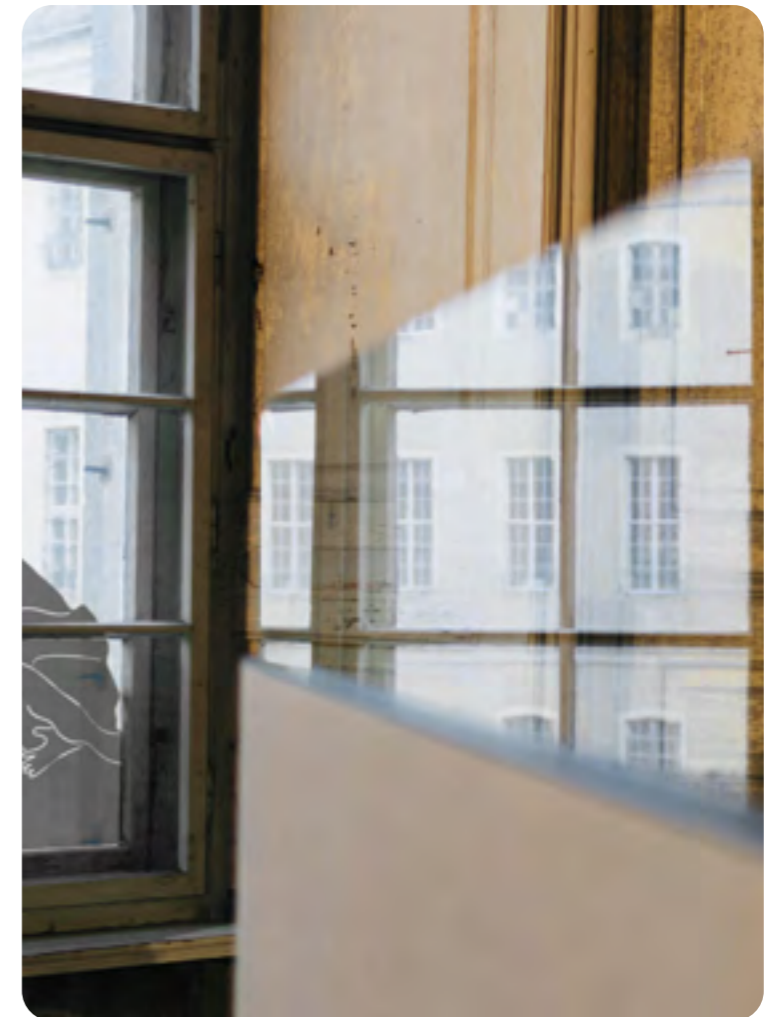

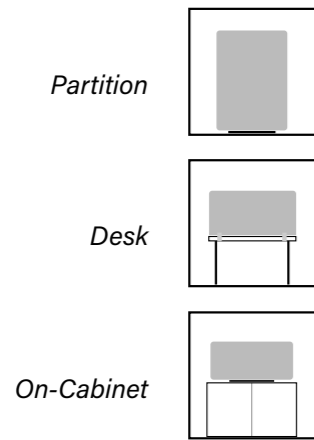

## Silence Line

### *Highly flexible & dynamic*

Noise in the office is more than an annoying disruptive factor. Constantly present, it measurably impairs work performance and ultimately also the health of employees. The **Silence Line** system partition wall, with its table top and on-cabinet elements as well as behind-desk elements, makes a decisive contribution to optimising room acoustics and improving noise protection at the workplace. Highly sound-absorbent at its core and a guarantor of the best acoustic properties, **Silence Line** with its functional-dynamic Velcro connection also stands for flexibility and cost efficiency. Designed as a modular system, glass walls and partially glazed walls are available in addition to fabric-covered walls. Organiser rails and electrification modules that can be integrated into the system offer a wide range of options for individual workstation design, including monitor swivel arms and glass topper. The partitions are offered in thicknesses of 55 and 40 mm, and thus also with different sound absorption

capacities. The use of **Silence Line**, a great deal of benefit can be achieved with little effort, which has a clearly positive effect on the work results, the well-being of the employees and ultimately the economic success of a company.

**Silence Line** shows its special characteristics through the uniquely flexible Velcro connection of the partitions. The ingenious angles of the connecting elements shorten the tool-free assembly and allow for quick conversion work on site. During development and material selection, the requirements for long-lasting and flexible use were taken into account. There is a choice of 3 different Velcro and velour colours, 18 fabric collections, 8 decorative surfaces and, in addition to clear and satin glass, also individual foiling and digitally printed fabric surfaces.



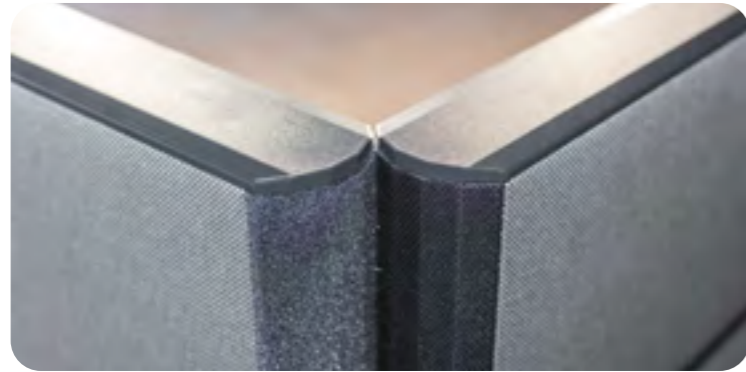

*Silence Line – Quick conversion thanks to uniquely flexible Velcro connection.*

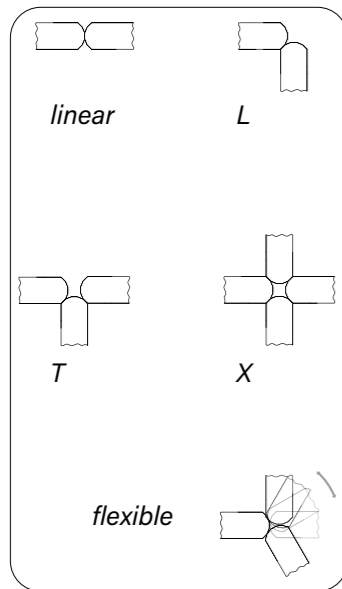

Connection options



*Silence Line movable walls offer a wide range of options for individual workplace design and improve acoustics.*



*Feet and foot stabilisers with integrated height compensation ensure a secure stand and allow unhindered circulation of the room air.*

Silence Line 55/40

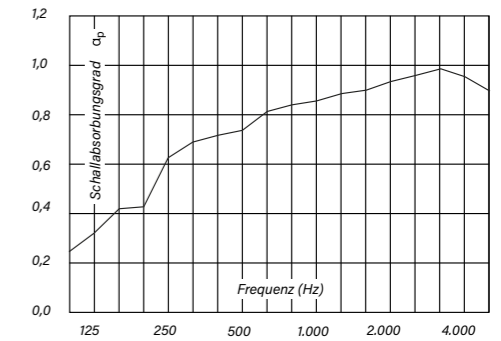

Sound absorption level - octave centre frequency (55 mm)

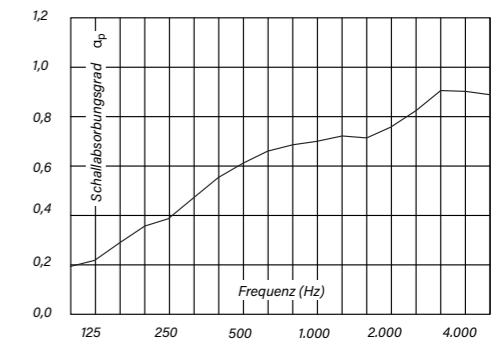

Sound absorption level - octave centre frequency (40 mm)



*The very broad modular system also includes closed decorative walls and integrated whiteboards, leaving nothing to be desired in terms of functionality.*

---

*Silence Line  
combines acoustics  
with flexibility and  
cost efficiency.*

With a wall thickness of 40 mm, positioned on sideboards or on a workbench, **Silence Line** on-cabinet elements always contribute to visual and acoustic shielding in the immediate working environment.



Rear desk screen

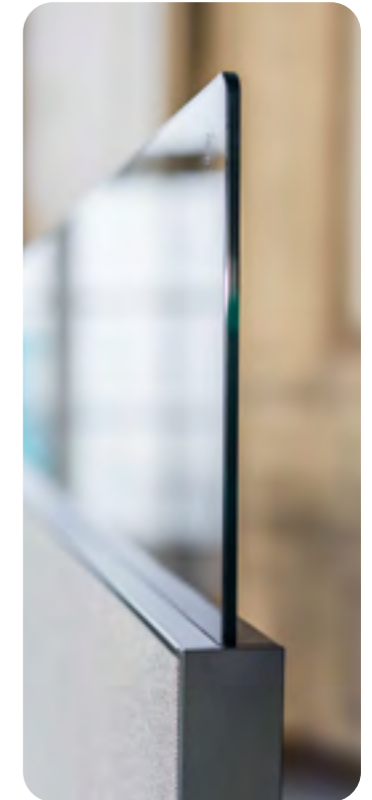

The desk and rear desk elements in the **Silence Line** series are available in a thickness of 40 mm, in various heights and seven standard widths. In addition, they can be customised to any table size and arrangement.



Attachment of the rear desk screens also to height-adjustable tables

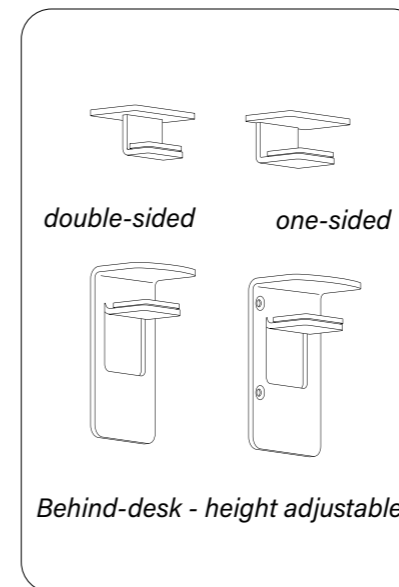

Connecting elements

Glass topper increase the sound-insulating effect while maintaining transparency.

[Silence Line >>](#)

*Impressum*

*published by*  
*Akustik Office Systeme GmbH*  
*Lenabergweg 5*  
*D-91626 Schopfloch*

*Editor*  
*Henrik Behnert, AOS*

*Graphics / Illustration*  
*Sabine Fleischmann, AOS*

*Photos*  
*Damian Tauchert, Berlin*  
*for AOS*

*@2026*

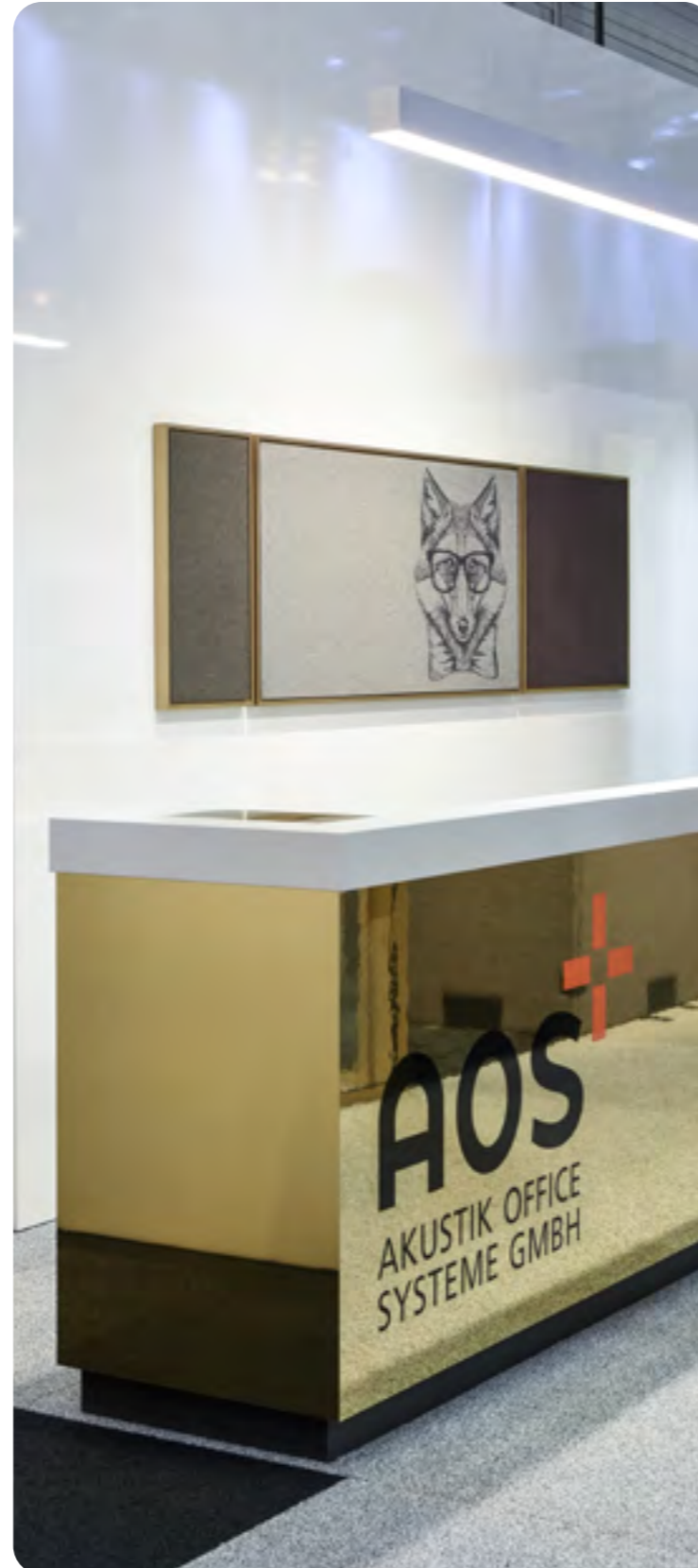

---

*Akustik Office Systeme GmbH*  
*Lenabergweg 5*  
*91626 Schopfloch*  
*Germany*

*Phone +49 9857 97559-0*

*Fax +49 9857 97559-29*

*[info@akustik-office-systeme.de](mailto:info@akustik-office-systeme.de)*

*[www.akustik-office-systeme.de](http://www.akustik-office-systeme.de)*